

Molatrice bilaterale

F

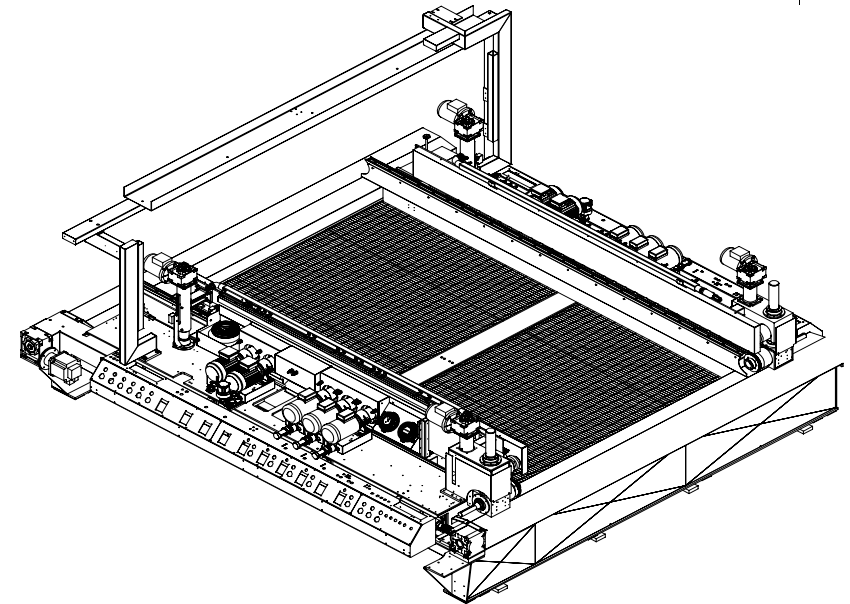

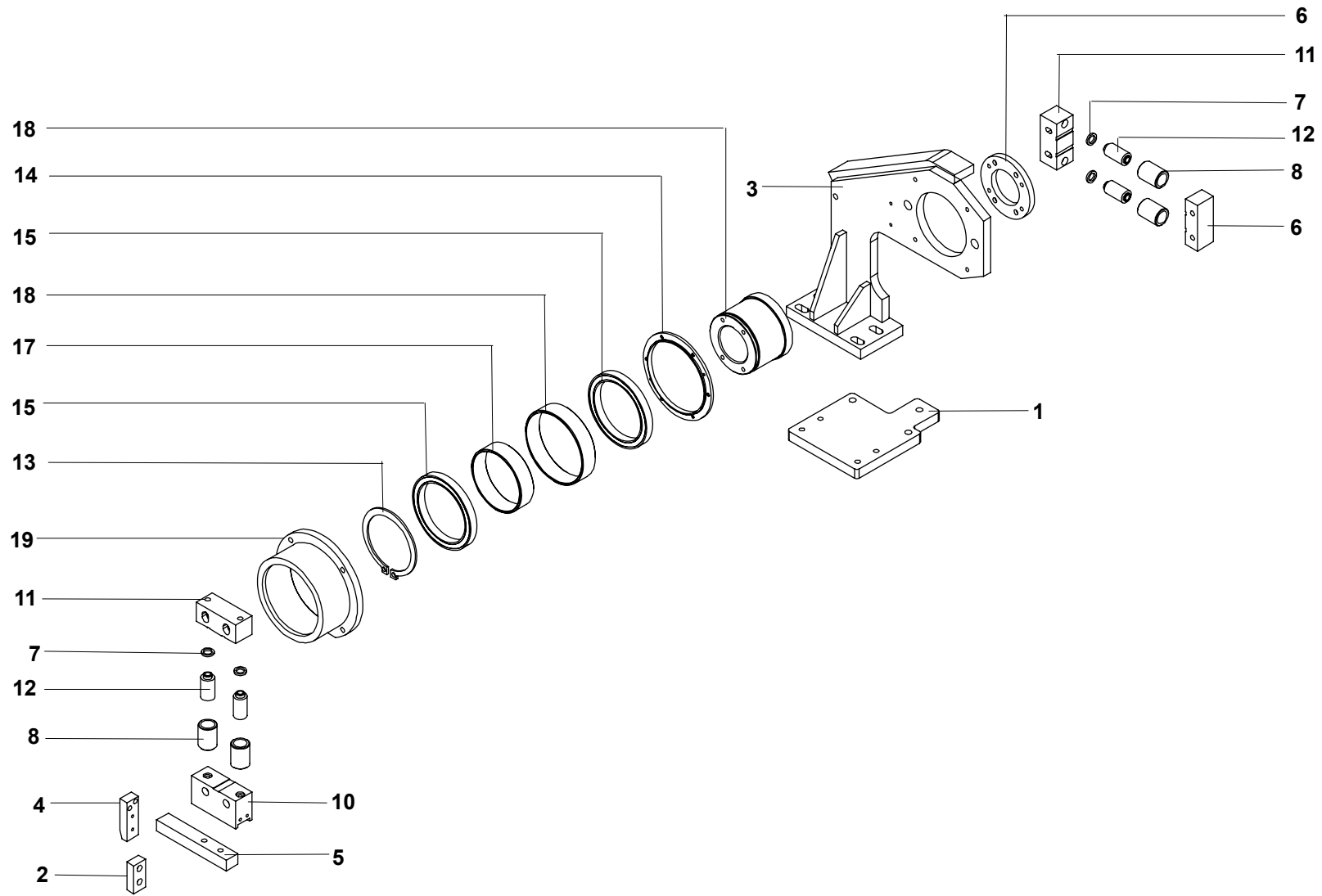

Pos.	Codice	Descrizione	Description
1		Supporto	Support
2		Riscontro	Reference part
3		Spalla	Shoulder
4		Piatto	Plate
5		Piatto	Plate
6		Flangia	Flange
7		Anello	Ring
8		Anello	Ring
9		Blocchetto	Block
10		Blocchetto	Block
11		Blocchetto	Block
12		Distanziale	Spacer
13		Seeger	Circlip
14		Flangia	Flange
15		Cuscinetto	Bearing
16		Anello	Ring
17		Anello	Ring
18		Corpo	Casing
19		Campana	Support

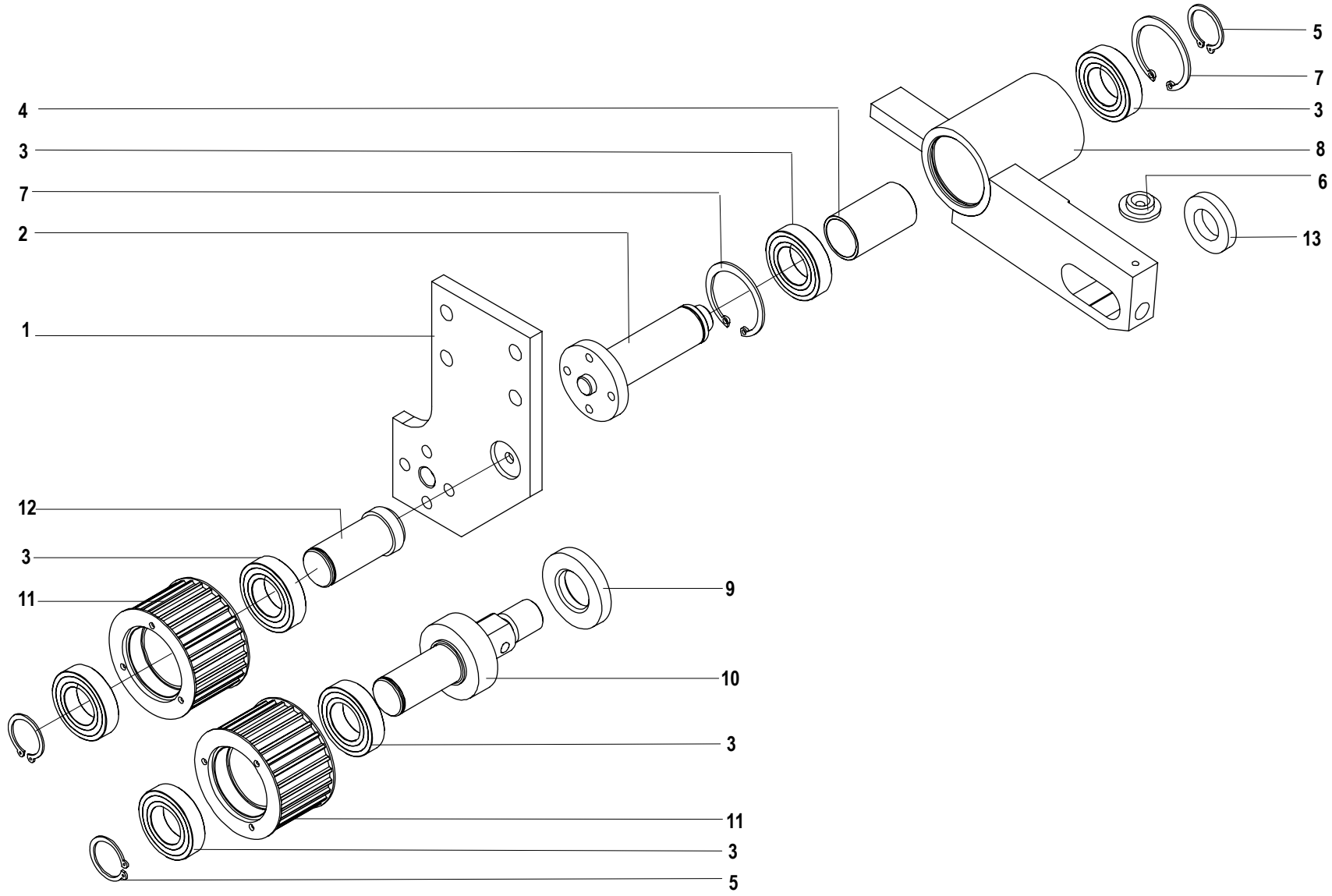

Pos.	Codice	Descrizione	Description
1		Piastra	Plate
2		Perno	Pivot
3		Cuscinetto	Bearing
4		Distanziale	Spacer
5		Anello	Ring
6		Rondella	Washer
7		Anello	Ring
8		Braccetto	Arm
9		Anello	Ring
10		Perno	Pivot
11		Puleggia	Pulley
12		Perno	Pivot
13		Rondella	Washer

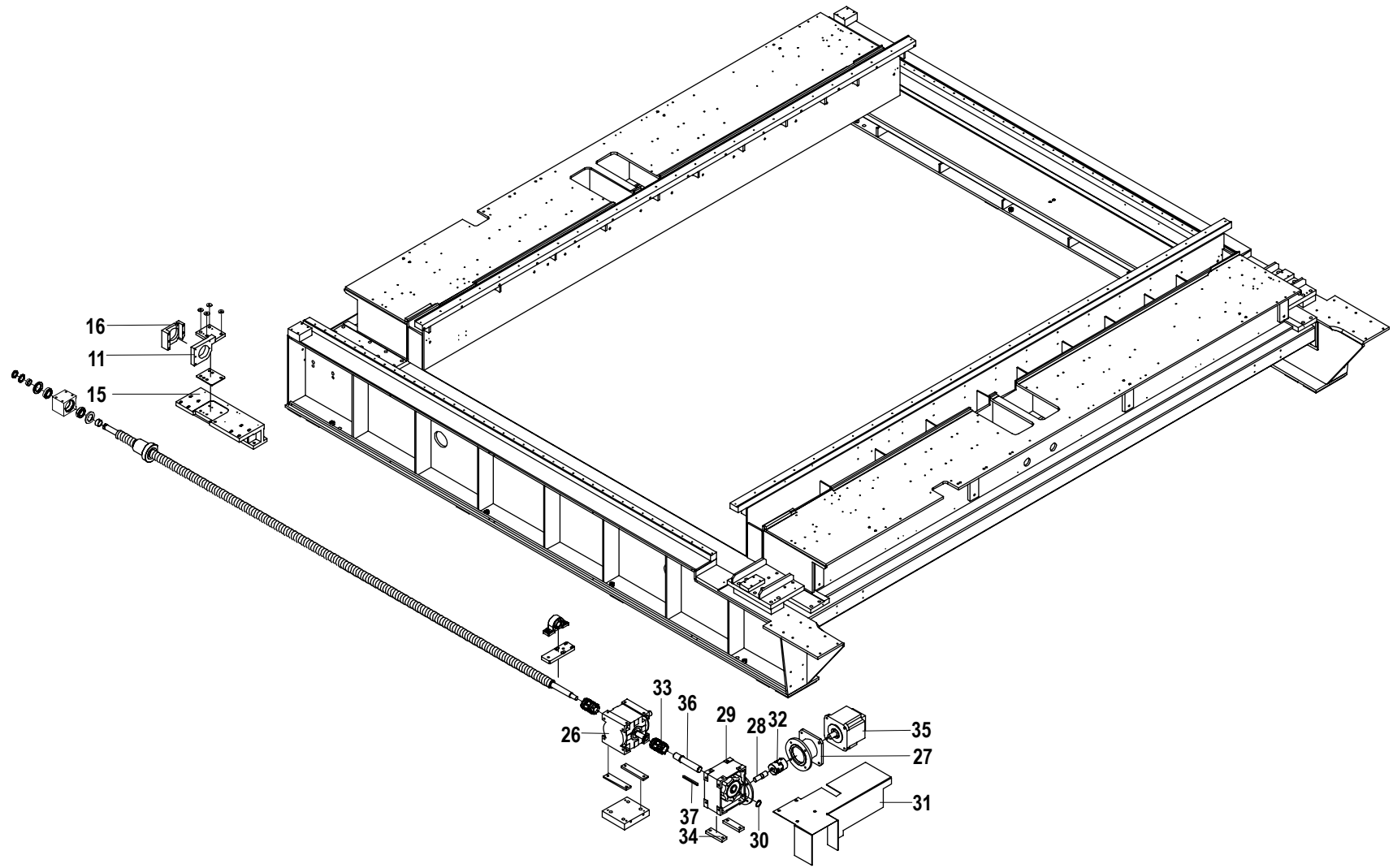

Pos.	Codice	Descrizione	Description
11		Supporto	Support
15		Sostegno	Support
16		Flangia	Flange
17		Supporto	Support
18		Flangia	Flange
19		Vite	Screw
26		Rinvio	Transmission
27		Campana	Support
28		Alberino	Small shaft
29		Riduttore	Gear box
30		Seeger	Circlip
31		Carter	Cover
32		Giunto	Joint
33		Giunto	Joint
34		Rasamento	Shim
35		Servomotore	Servomotor
36		Albero	Shaft
37		Linguetta	Feather key

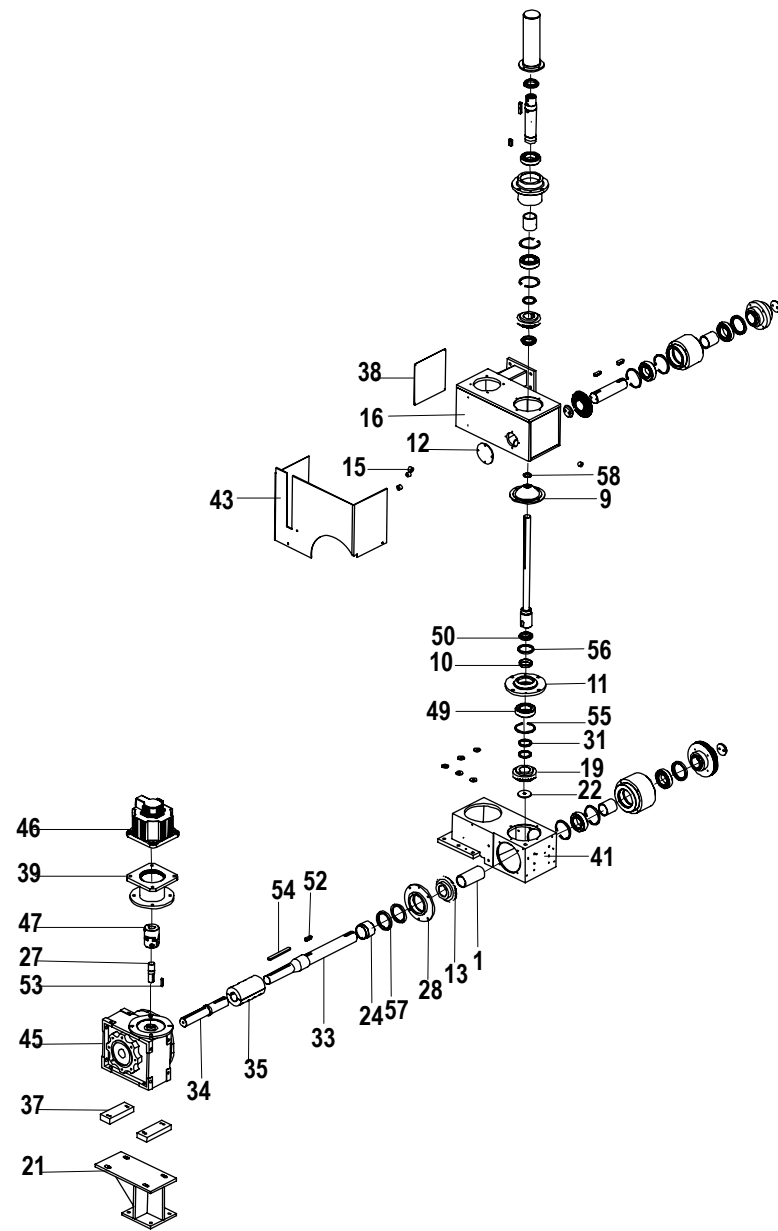

Pos.	Codice	Descrizione	Description
1		Distanziale	Spacer
6		Linguetta	Feather key
9		Campana	Support
10		Distanziale	Spacer
11		Corpo	Casing
12		Flangia	Flange
13		Pignone	Pinion
15		Distanziale	Spacer
16		Scatola	Box
22		Rondella	Washer
24		Anello	Ring
28		Flangia	Flange
31		Anello	Ring
33		Albero	Shaft
38		Carter	Cover
41		Scatola	Box
43		Carter	Cover
50		Ghiera	Ring nut
52		Linguetta	Feather key
54		Linguetta	Feather key
56		Anello	Ring

Pos.	Codice	Descrizione	Description
57		Anello	Ring
58		Anello	Ring

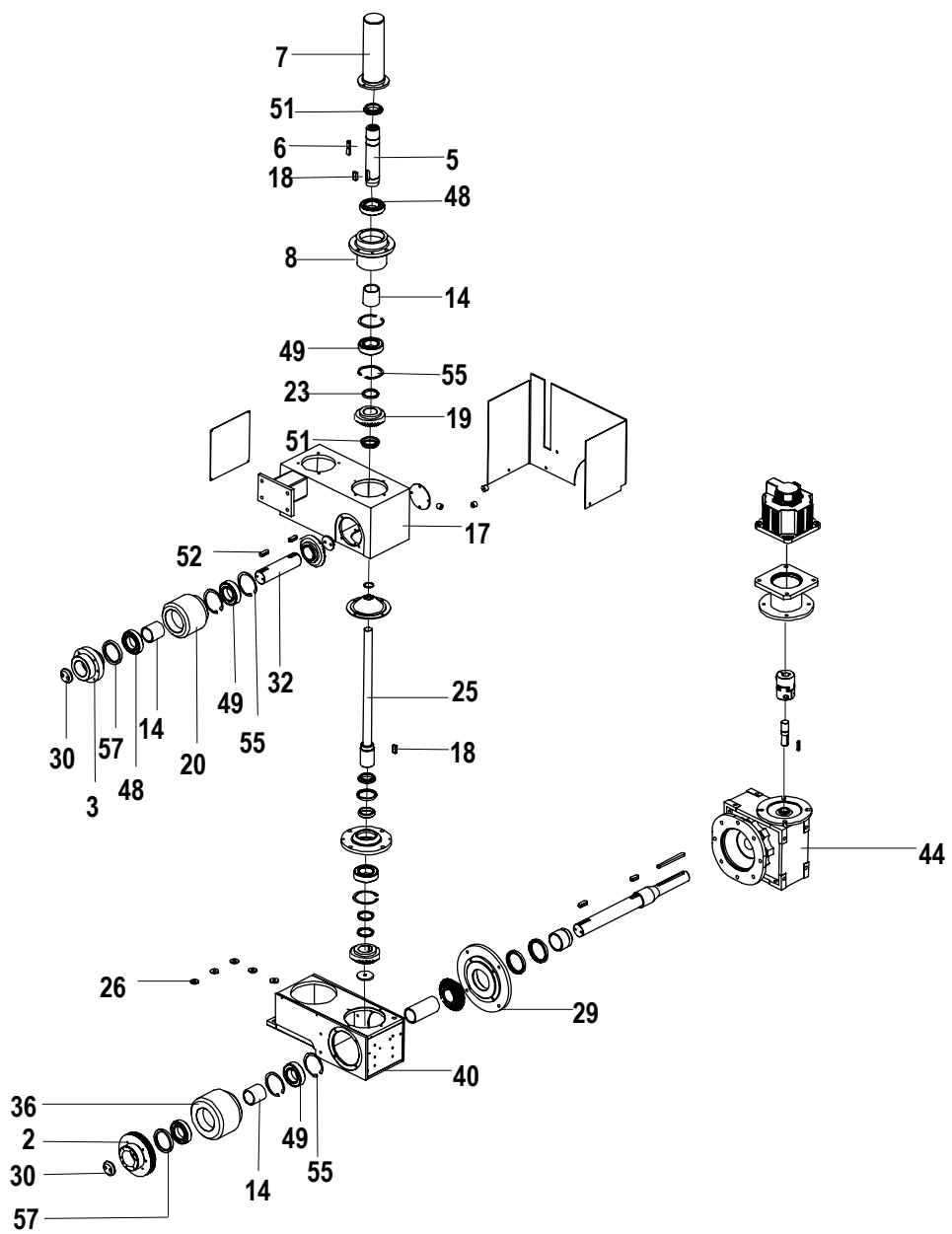

Pos.	Codice	Descrizione	Description
2		Cannotto	Sleeve
3		Cannotto	Sleeve
4		Pignone	Pinion
5		Cannotto	Sleeve
7		Protezione	Guard
8		Corpo	Casing
14		Distanziale	Spacer
17		Scatola	Box
18		Linguetta	Feather key
19		Pignone	Pinion
20		Mozzo	Hub
21		Motore	Motor
23		Anello	Ring
25		Albero	Shaft
26		Rondella	Washer
27		Alberino	Shaft
29		Flangia	Flange
30		Rondella	Washer
32		Albero	Shaft
34		Albero	Shaft

Pos.	Codice	Descrizione	Description
35		Giunto	Joint
36		Mozzo	Hub
37		Spessore	Thickness
39		Campana	Bell
40		Scatola	Box
42		Carter	Carter
44		Riduttore	Reduction gear
45		Riduttore	Reduction gear
46		Motore	Motor
47		Giunto	Joint
48		Cuscinetto	Bearing
49		Cuscinetto	Bearing
50		Ghiera	Ring nut
51		Ghiera	Ring nut
53		Linguetta	Languette
55		Seeger	Seeger

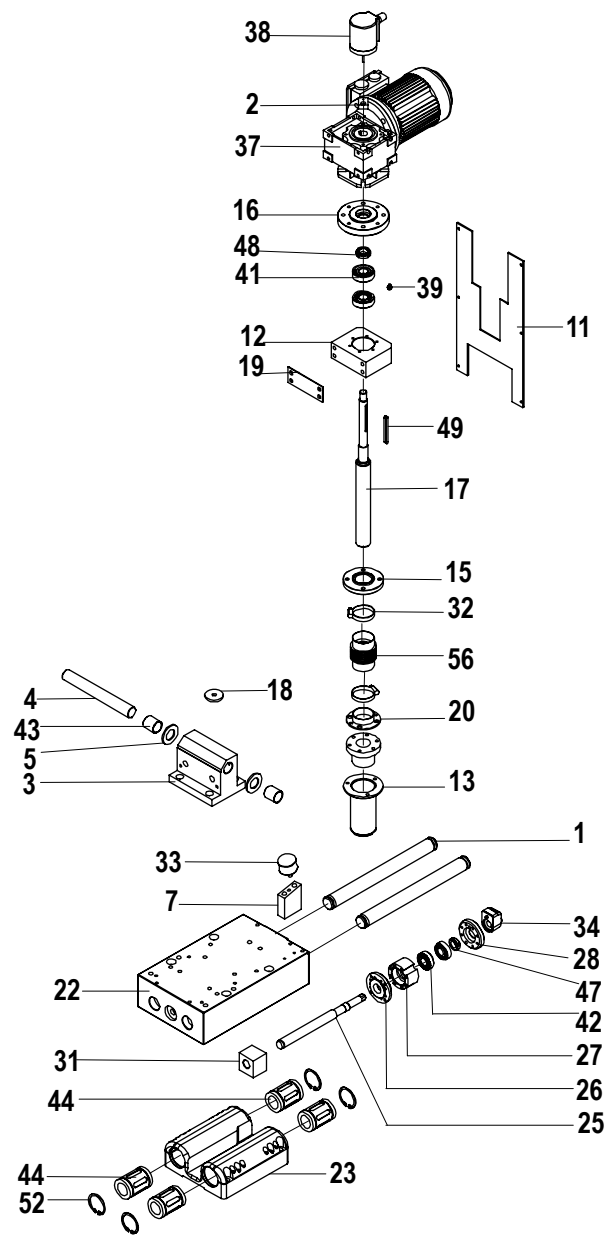

Pos.	Codice	Descrizione	Description
1		Albero	Shaft
2		Piatto	Plate
3		Supporto	Support
4		Albero	Shaft
5		Rondella	Washer
7		Distanziale	Spacer
11		Carter	Cover
12		Blocchetto	Block
13		Canocchiale	Bush
15		Flangia	Flange
16		Flangia	Flange
17		Vite	Screw
18		Rondella	Washer
19		Spessore	Thickness
20		Collare	Collar
22		Slitta	Slide
23		Corpo	Casing
25		Vite	Screw
26		Flangia	Flange
27		Flangia	Flange
28		Flangia	Flange

Pos.	Codice	Descrizione	Description
31		Madrevite	Nut screw
32		Fascetta	Band
33		Puffer	Puffer
34		Indicatore	Indicator
37		Motoriduttore	Geared motor
38		Encoder	Encoder
39		Ingrassatore	Lubricator
41		Cuscinetto	Bearing
42		Cuscinetto	Bearing
43		Manicotto	Sleeve
44		Manicotto	Sleeve
47		Ghiera	Ring nut
48		Ghiera	Ring nut
49		Linguetta	Feather boy
52		Seeger	Circlip
56		Soffietto	Bellows

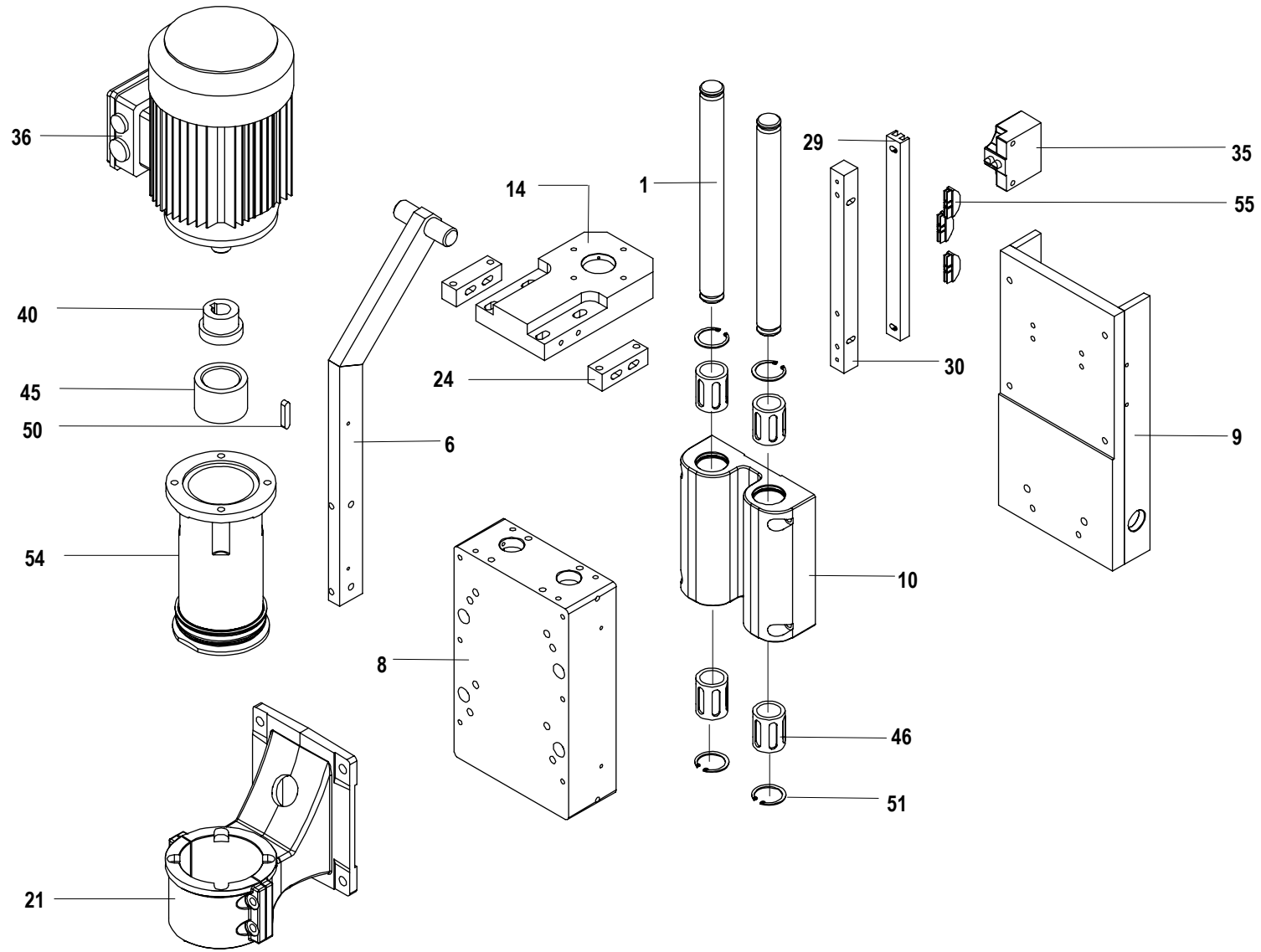

Pos.	Codice	Descrizione	Description
1		Albero	Shaft
6		Leva	Lever
8		Slitta	Slide
9		Piastra	Plate
10		Corpo	Casing
14		Supporto	Support
21		Supporto	Support
24		Blocchetto	Block
29		Guida	Guide
30		Blocchetto	Block
35		Finecorsa	Limit switch
36		Motore	Motor
40		Mozzo	Hub
45		Manicotto	Sleeve
46		Manicotto	Sleeve
50		Linguetta	Feather key
51		Seeger	Seeger
53		Anello	Ring
54		Gruppo	Group
55		Camma	Camme

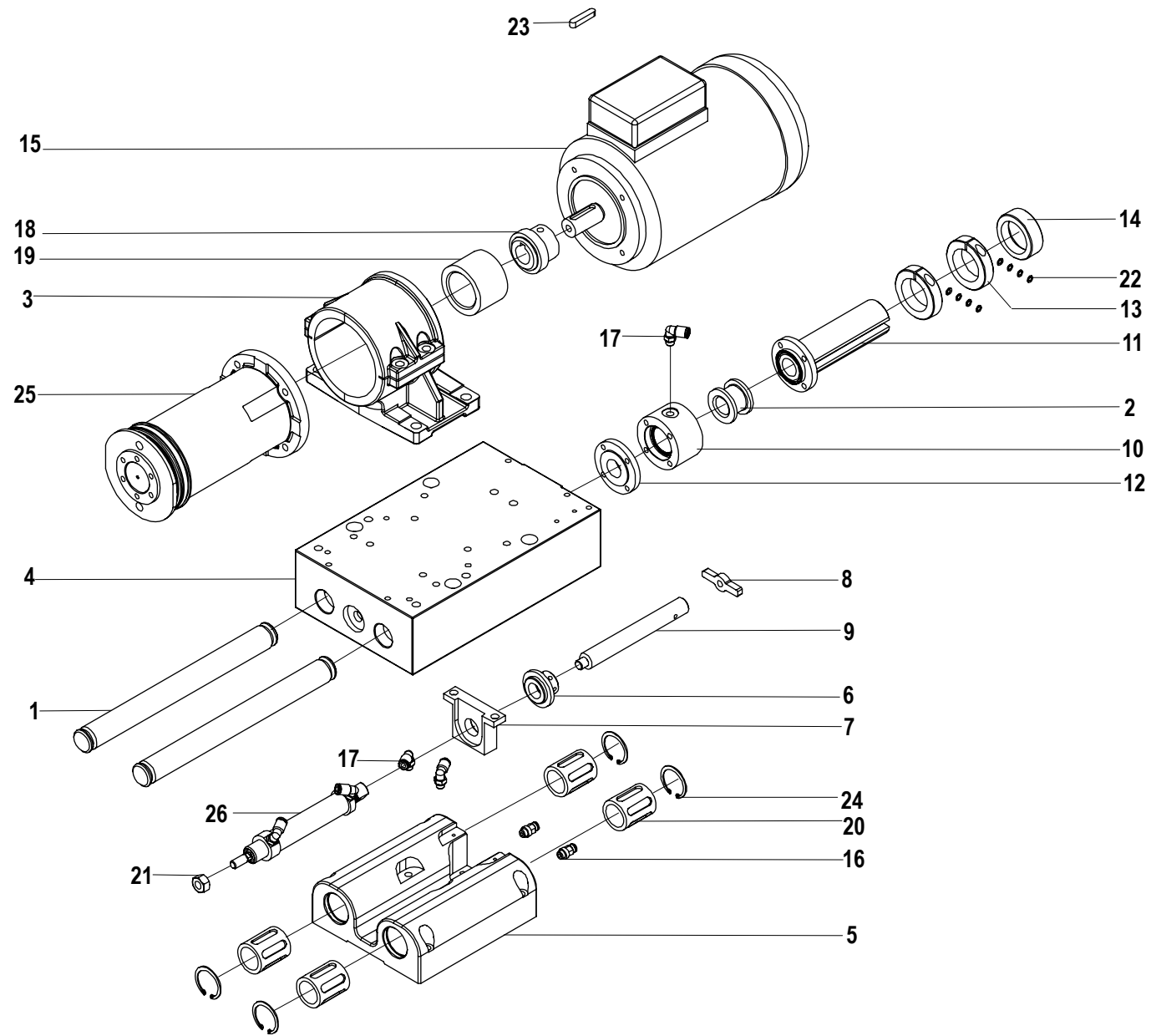

Pos.	Codice	Descrizione	Description
1		Albero	Shaft
2		Freno	Brake
3		Supporto	Support
4		Slitta	Slide
5		Corpo	Casing
6		Boccola	Bush
7		Attacco	Fitting
8		Chiavetta	Key
9		Stelo	Stem
10		Corpo	Casing
11		Flangia	Flange
12		Flangia	Flange
13		Anello	Ring
14		Ghiera	Ring nut
15		Motore	Motor
16		Raccordo	Fitting
17		Gomito	Elbow
18		Mozzo	Hub
19		Manicotto	Sleeve
20		Manicotto	Sleeve
21		Dado	Nut

Pos.	Codice	Descrizione	Description
22		Schnoor	Schnoor
23		Linguetta	Feather key
24		Seeger	Circlip
25		Gruppo	Group
26		Gruppo	Group

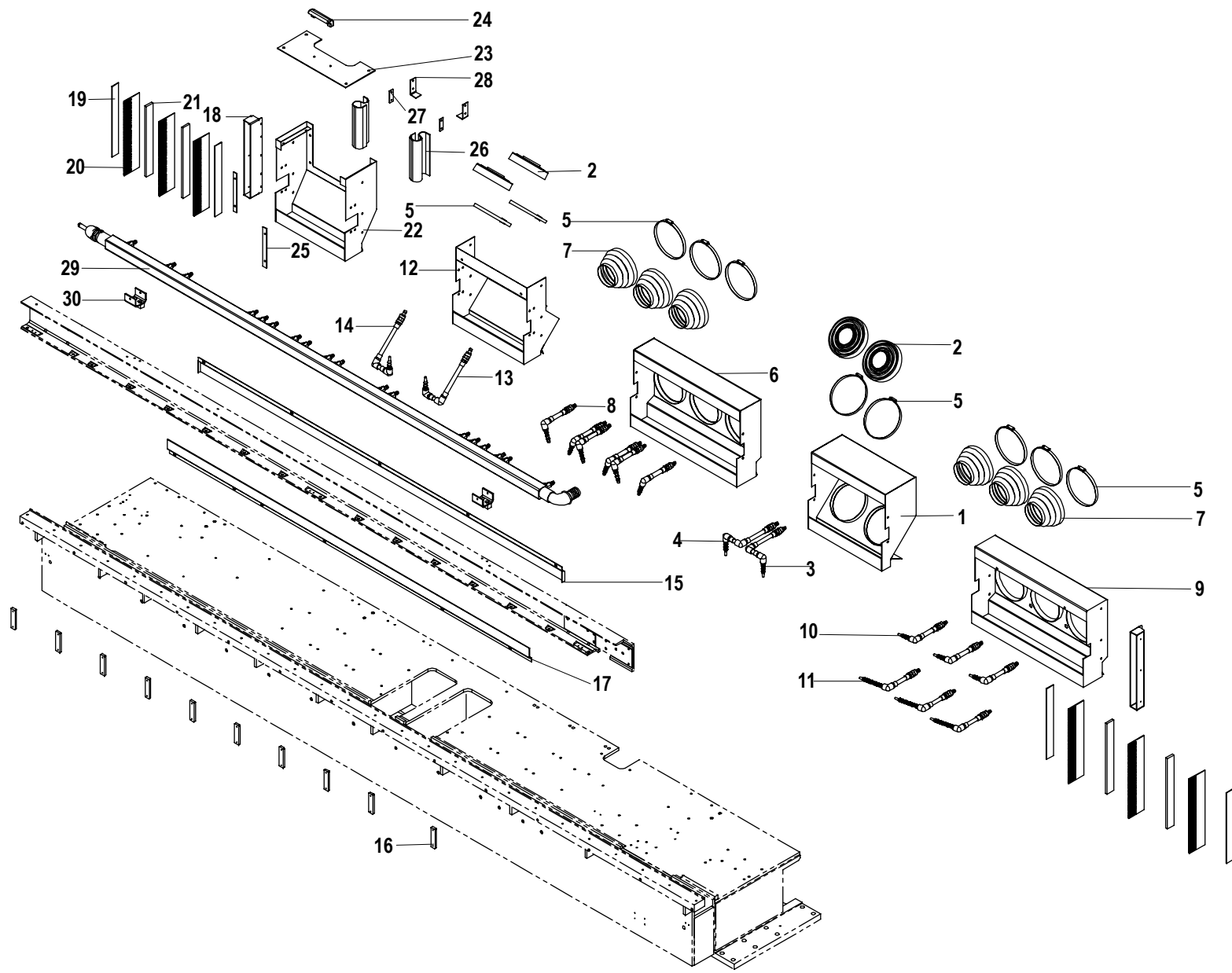

Pos.	Codice	Descrizione	Description
1		Carter	Cover
2		Soffietto	Bellows
3		Tubo	Tube
4		Tubo	Tube
5		Fascetta	Clamp
6		Carter	Carter
7		Soffietto	Bellows
8		Tubo	Tube
9		Carter	Cover
10		Tubo	Tube
11		Tubo	Tube
12		Carter	Cover
13		Tubo	Tube
14		Tubo	Tube
15		Labirinto	Labyrinth
16		Piatto	Plate
17		Labirinto	Labyrinth
18		Carter	Cover
19		Distanziale	Spacer
20		Gomma	Rubber
21		Carter	Cover

Pos.	Codice	Descrizione	Description
22		Carter	Cover
23		Coperchio	Cover
24		Maniglia	Handle
25		Piatto	Plate
26		Gomma	Rubber
27		Piatto	Plate
28		Squadretta	Square
29		Tubo	Tube
30		Staffe	Bracket

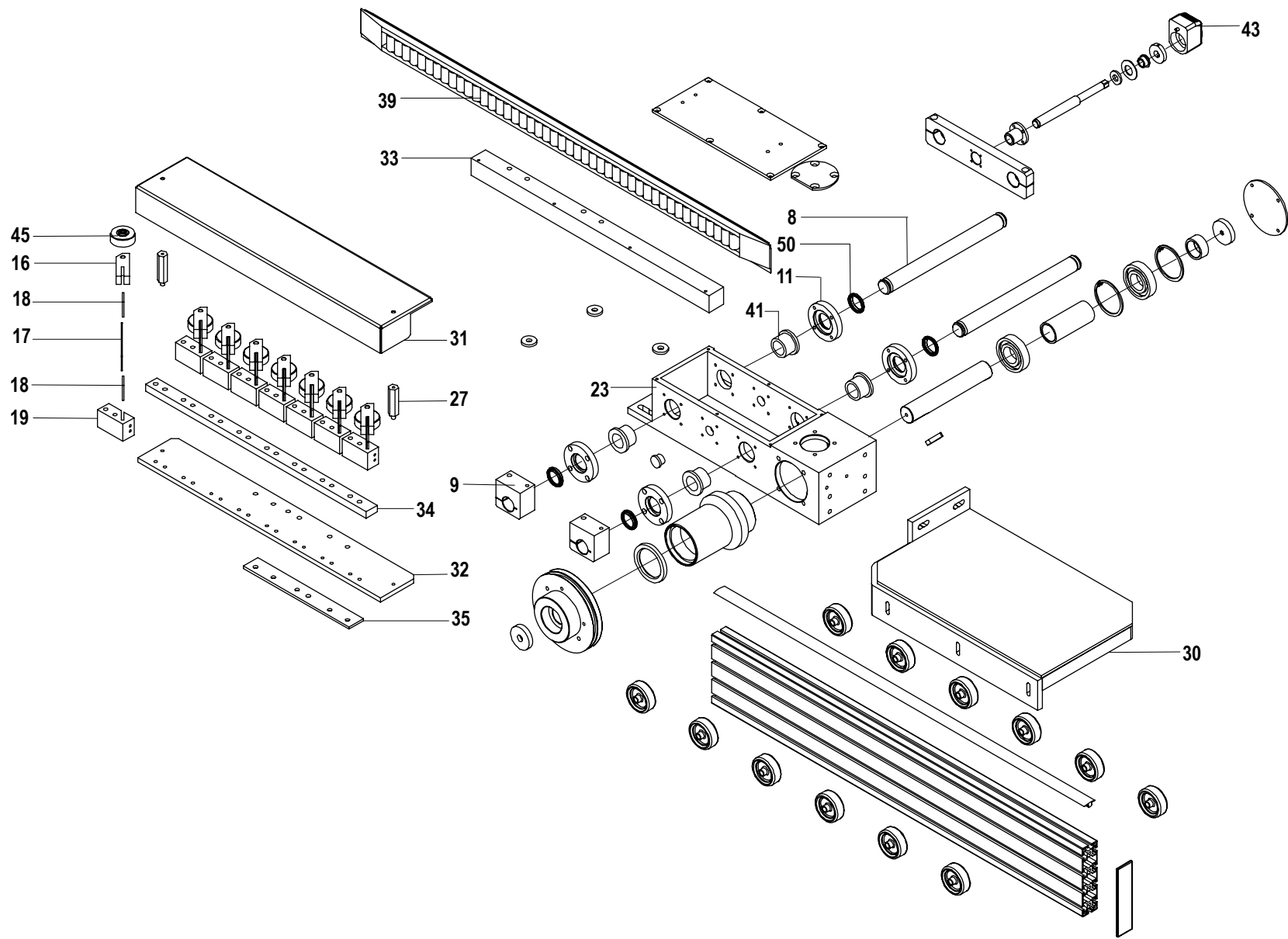

Pos.	Codice	Descrizione	Description
8		Albero	Shaft
9		Blocchetto	Block
11		Flangia	Flange
16		Piatto	Plate
17		Lamina	Foil
18		Piatto	Plate
19		Piatto	Plate
23		Scatola	Box
27		Colonna	Column
30		Mensola A	Bracket
31		Carter	Cover
32		Piatto	Plate
33		Barra	Bar
34		Piatto	Plate
35		Spessore	Thickness
39		Rulliera	Roller conveyer
41		Boccola	Bush
43		Ruota	Wheel
45		Ruota	Wheel
50		Anello	Ring

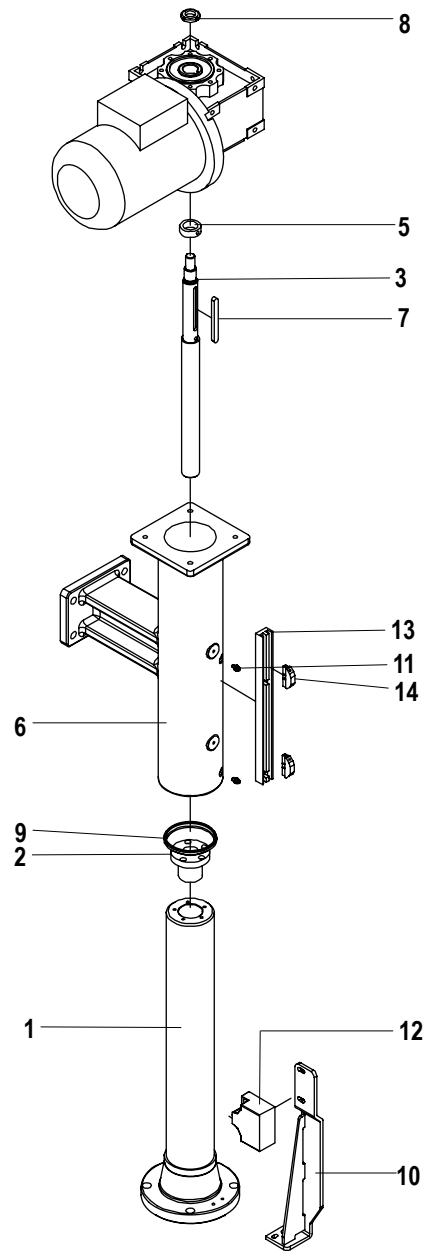

Pos.	Codice	Descrizione	Description
1		Colonna	Column
2		Chiocciola	Screw nut
3		Vite	Screw
4		Motoriduttore	Geared box
5		Anello	Ring
6		Supporto	Support
7		Linguetta	Feather key
8		Ghiera	Ring nut
9		Anello	Ring
10		Supporto	Support
11		Ingrassatore	Lubricator
12		Finecorsa	Limit switch
13		Guida	Guide
14		Camma	Cam

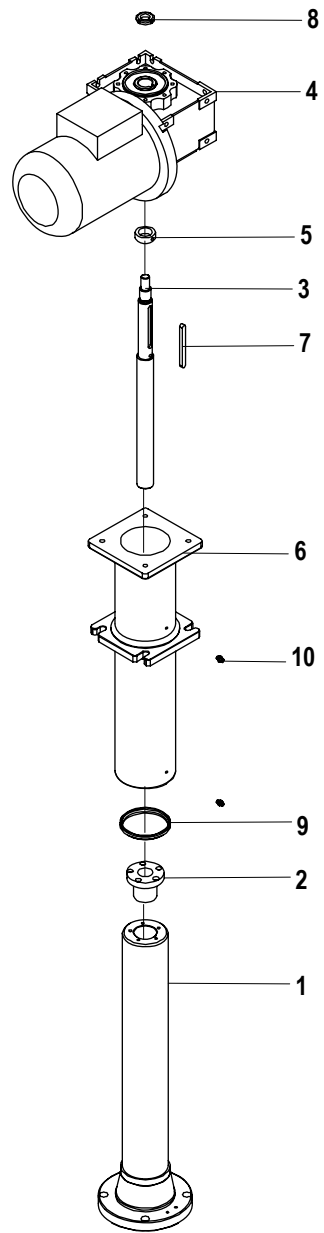

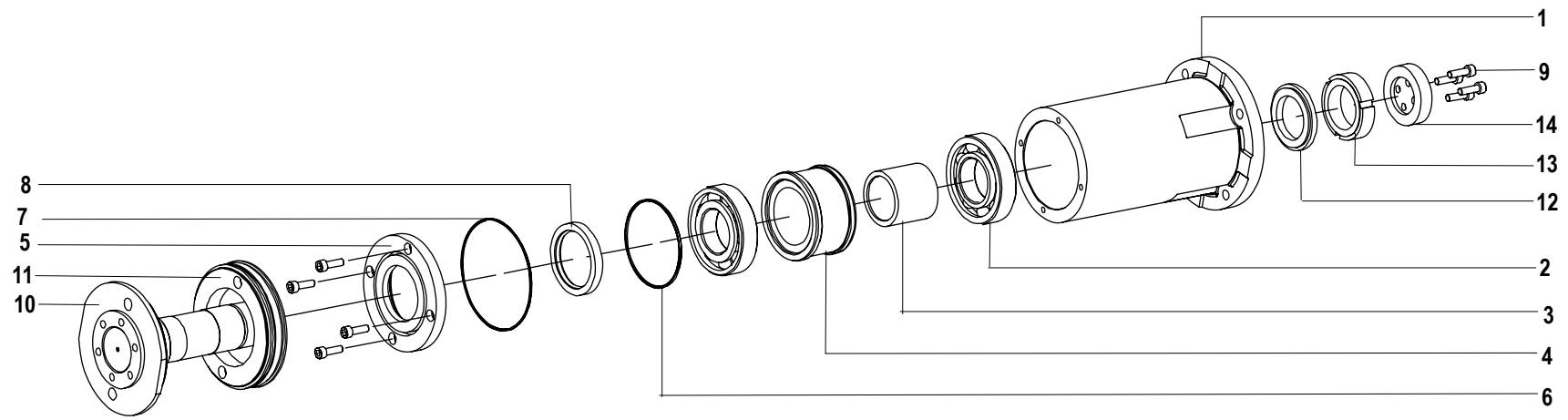

Pos.	Codice	Descrizione	Description
1		Corpo	Casing
2		Coppia	Pair
3		Distanziale	Spacer
4		Distanziale	Spacer
5		Flangia	Flange
6		Guarnizione	Seal
7		Cordino	Thin ring
8		Anello	Ring
9		Vite	Screw
10		Albero	Shaft
11		Anello	Ring
12		Anello	Ring
13		Ghiera	Ring nut
14		Giunto	Joint

